



DIARY

COMPANY FOR GENERAL TRADING
AGENCY AND SUPPLYING AND
INSTALLING GENERATOR / LTD

MEER POWER
GENERATOR

Perkins®

MEER1650 ^{KVA}

GENERATOR DATASHEET

ENGINE

WE ARE THE AUTHORIZED OEM OF PERKINS. PERKINS HAS THE HIGHEST STANDARD OF ENGINEERING IT PROVIDES MOST COMPREHENSIVE AND RELIABLE POWER SOLUTION; ITS PRODUCTS MEET THE PRECISE REQUIREMENTS OF CUSTOMERS; PERKINS IS A UK BASED COMPANY WITH HISTORY OF 85 YEARS; IT'S ONE OF THE LEADING PROVIDER OF GAS AND DIESEL THE WORLD ENGINES.

ALTERNATOR

WE OFFER WORLD WELL-KNOWN ALTERNATOR SUCH AS LEROY SOMER, STAMFORD FOUR POLE BRUSHLESS SELF-EXCITED SYSTEM, CLASS H INSULATION; THE VOLTAGE REGULATION WILL BE 1%. IF PMG SYSTEM IS SELECTED, THE VOLTAGE REGULATION WILL BE 0.5%, AND AT THE SAME TIME PMG SYSTEM PROVIDES HIGH MOTOR STARTING CAPABILITY AS WELL AS IMMUNITY TO WAVEFORM DISTORTION.



ATS & SYNCRO

EASILY TO OPERATE
CONNECTION WITH
HIGH RELIABILITY.

BASE FRAME

FABRICATED, WELDED CONSTRUCTION FRAME. HIGH QUALITY MILD STEEL. INTEGRATED BASE FUEL TANK_ANTI-VIBRATION SYSTEM. LIFTING SYSTEM. PAINTED (POWER COATED OR EPOX SPRAY PAINTED).

CONTROL PANEL

NGT GENERATORS ARE PROVIDED WITH DSE INTEGRATED CONTROL PANEL. IT IS RESPONSIBLE FOR MONITORING AND PROTECTION OF GENERATOR.



STANDARD SPECIFICATIONS

1. ENGINE

Perkins four stroke heavy duty high performance industrial type diesel engine.

2.ENGINE FILTRATION SYSTEM

- Cartridge type dry air filter.
- Cartridge type fuel filter.
- Full flow lube oil filter.
- Water filter.

All filters have replaceable elements.

3. COOLING RADIATOR

Radiator and cooling fan, complete it safety guards, designed to cool the engine at high ambient temperatures (consult your dealer for de-ration factors).

4. EXHAUST SYSTEM

Heavy duty Industrial Exhaust Silencer.

5. CIRCUIT BREAKER TYPE

ABB 3 pole MCCB. (4 pole is optional).

GENERATING SET MODEL

Output Ratings

	Prime	Standby
380-415 V, 3 ph, 50 Hz, 1500 rpm	1500 KVA	1650 KVA
	1200 KW	1320 KW

Applicable Voltages: 220/127 V at 60 Hz only (Consult your dealer for more details).
* Ratings at 0.8 Power Factor

ENGINE / TECHNICAL DATA

Engine Make	Perkins	
Engine Model	4012 - 46TAG2A	
Governing Type	Digital	
Number of Cylinders	12	
Cylinder Arrangement	60° Vee form	
Bore and Stroke mm	160 x 190	
Displacement / Cubic Capacity litres	45.842	
Induction System	Turbocharged and air to air charge cooled	
Cycle	4 stroke	
Combustion System	Direct Injection	
Compression Ratio	13.6:1	
Rotation	Anti-clockwise, viewed from flywheel end	
Cooling System	Water - cooled	
Frequency and Engine Speed	50Hz & 1500rpm	
	Prime	Standby
Gross Engine Power kW (hp)	1331 (1785)	1459 (1957)
Fuel Consumption @ 50% load L/hr	162	-
@ 75% load L/hr	237	- 335
@ 100% load L/hr	301	
Total Lubrication System Capacity litres	177	177
Total Coolant Capacity litres	210	210
Boost Pressure Ratio	3.1	3.4
Exhaust Temperature: °C	455	455
Radiator Cooling Air Flow (Min): m3/sec	32.4	32.4
Combustion Air Flow: m3/min	120	128
Exhaust Gas Flow: m3/min	320	320

ALTERNATOR DATA

Make	Model
Leroy Somer	LSA50.2L8
Stamford	PI 734 C
No. of bearings	1
Insulation class	H
Total Harmonic Content	<2.5%
Wires	12
Ingress Protection	IP23
Over speed	2250 mn-1
Voltage Regulation	3 0.5%

Features

Size	LXWXH (CM)	Weight (kg)
Open Type	480*220*240	10550

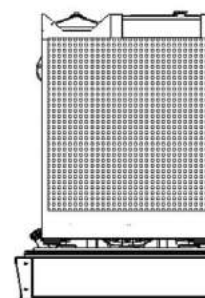
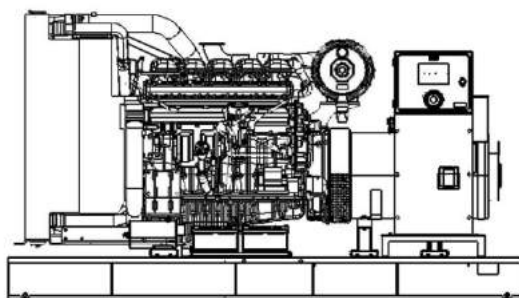
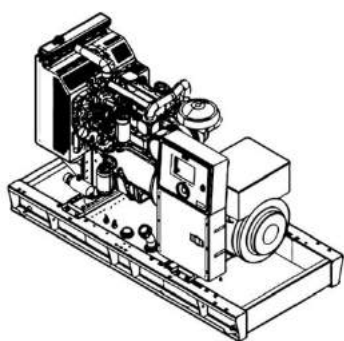

Control Panel

The DSE7320 is an Auto Start Control Module for single genset applications. It includes a backlit LCD display which clearly shows the status of the engine all the times. This module can either be programmed using the front panel or by using the DSE configuration suite PC software.

Metering and Alarm indications:

- Generator frequency
- Under speed, Over speed
- Generator volts (L-L, L-N)
- Generator current
- Engine oil pressure
- Engine coolant temperature

- Hours run counter
- Battery volts
- Fail to start/stop
- Emergency stop
- Charge fail
- CAN diagnostics and CAN fail/error



RATINGS DEFINITION

Prime Power

These ratings are applicable for supplying continuous electrical power (at variable load) in lieu of commercially purchased power. 10% overload power is available for 1 hour in 12 hours continuous operation.

Standby Power

These ratings are applicable for supplying continuous electrical power (at variable load) in the event of a utility power failure. No overload is permitted on these ratings

STANDARD REFERENCE CONDITIONS

Output ratings are presented at 25°C air inlet temperature, barometric pressure 100 kPa, relative humidity 30%. This generating set is designed to operate at high ambient temperatures (up to 55°C), humidity (up to 99%) and higher altitudes. De-ration may apply, please consult your dealer for specific site ratings.

AVAILABLE OPTIONS & ACCESSORIES

We offer a range of optional features and accessories to tailor our generating sets to meet your power needs.

ACCESSORIES

- Genuine spare parts
- Auxiliary fuel tanks
- Manual & automatic transfer switches

OPTIONS

- A variety of generating set control and synchronizing panels
- Water fuel separator
- Water jacket heater
- Battery charger

- Due to continuous product development we reserve the right to change specifications at any time without prior notice

STANDARD SPECIFICATIONS

6. ALTERNATOR

6.1 INSULATION SYSTEM

The insulation system is Class H. All windings are impregnated in either a triple dip thermosetting liquid, oil and acid resisting polyester varnish or vacuum pressure impregnated with a special polyester resin.

- Heavy coat of antitracking varnish additional protection against moisture or condensation.

6.2 AUTOMATIC VOLTAGE REGULATOR (AVR)

The fully sealed Automatic Voltage Regulator maintains the Voltage Regulation at 30.5%. Nominal adjustment by means of a trim pot incorporated on the AVR.

6.3 MOTOR STARTING

An overload capacity equivalent to 300% of the Full Load impedance at zero Power Factor can be sustained for 10 seconds, when AREP or PMG option is fitted.

7. MOUNTING ARRANGEMENT

7.1 BASE FRAME

The complete Generating Set is mounted as a whole on a heavy duty fabricated steel Baseframe.

7.2 COUPLING

The Engine and Alternator are directly coupled by means of an SAE flange. The Engine flywheel is flexibly coupled to the Alternator rotor.

7.3 ANTI-VIBRATION MOUNTING PADS Anti-Vibration pads are affixed between the Engine / Alternator feet and the Base frame thus ensuring complete vibration isolation of the rotating assembly.

7.4 SAFETY GUARDS

The Fan & Fan Drive along with the Battery Charging Alternator are Safety Guard protected for personnel protection.

8. FACTORY TESTS

The Generating set is load tested before dispatch. All protective devices control functions and site load conditions are simulated. The generator and it's systems are checked before dispatch.

9. EQUIPMENT FINISHING

All mild steel components are fully degreased and painted with powder coated paint to ensure maximum scuff resistance and durability.



SULAYMANIYAH OFFICE

MAILK MAHMUD RING ROAD | NEAR BINAHEY OIL STATION |
SULAIMANYA | KRG-IRAQ TEL: 0964 750 155 3355



ERBIL OFFICE

MAKHMOR ROAD | KURRAN | OPPOSITE KHDR SWARA
MOSQUE | ERBILKRG-IRAQ | TEL : 0964 750 150 0527

FACTORY

SOUTH INDUSTRIAL AREA | TRACTOR INDUSTRIAL| ERBIL | KRG-IRAQ
TEL: 0964 750 050 0490

MUSL OFFICE

POTATO'S STORE POINT | BEHAND INDUSTRIAL HIGH
SCHOOL |3RD STREET | MUSL | IRAQ
TEL: 0964 770 201 2305

SPARE PART SULI

SARKAREZ | NEAR ASOI DALAK INTERSECTION | SULAIMANYA | KRG-IRAQ
TEL: 0964 773 150 3655

SPARE PART ERBIL

SOUTH INDUSTRIAL AREA| MID OF 3RD STREET | ERBIL | KRG-IRAQ
TEL: 0964 750 300 3355

SERVICE WORKSHOP

OLD INDUSTRIAL AREA | OPPOSITE AUBARA QRT. | SULAIMANYA | KRG-IRAQ
TEL: 0964 750 050 0285

WWW.DIARY-SUPPLIES.COM
INFO@DIARY-SUPPLIES.COM

