



# DIARY

COMPANY FOR GENERAL TRADING  
AGENCY AND SUPPLYING AND  
INSTALLING GENERATOR / LTD

MEER POWER  
GENERATOR

Perkins®

## MEER 400 <sup>KVA</sup>

GENERATOR DATASHEET

### ENGINE

WE ARE THE AUTHORIZED OEM OF PERKINS. PERKINS HAS THE HIGHEST STANDARD OF ENGINEERING IT PROVIDES MOST COMPREHENSIVE AND RELIABLE POWER SOLUTION; ITS PRODUCTS MEET THE PRECISE REQUIREMENTS OF CUSTOMERS; PERKINS IS A UK BASED COMPANY WITH HISTORY OF 85 YEARS; IT'S ONE OF THE LEADING PROVIDER OF GAS AND DIESEL THE WORLD ENGINES.

### ALTERNATOR

WE OFFER WORLD WELL-KNOWN ALTERNATOR SUCH AS LEROY SOMER, STAMFORD FOUR POLE BRUSHLESS SELF-EXCITED SYSTEM, CLASS H INSULATION; THE VOLTAGE REGULATION WILL BE 1%. IF PMG SYSTEM IS SELECTED, THE VOLTAGE REGULATION WILL BE 0.5%, AND AT THE SAME TIME PMG SYSTEM PROVIDES HIGH MOTOR STARTING CAPABILITY AS WELL AS IMMUNITY TO WAVEFORM DISTORTION.



### ATS & SYNCRO

EASILY TO OPERATE  
CONNECTION WITH  
HIGH RELIABILITY.

### BASE FRAME

FABRICATED, WELDED CONSTRUCTION FRAME. HIGH QUALITY MILD STEEL. INTEGRATED BASE FUEL TANK\_ANTI-VIBRATION SYSTEM. LIFTING SYSTEM. PAINTED (POWER COATED OR EPOX SPRAY PAINTED).

### CONTROL PANEL

NGT GENERATORS ARE PROVIDED WITH DSE INTEGRATED CONTROL PANEL. IT IS RESPONSIBLE FOR MONITORING AND PROTECTION OF GENERATOR.



### GENERATING SET MODEL Output Ratings

	Prime	Standby
380-415 V, 3 ph, 50 Hz, 1500 rpm	350 KVA	400 KVA
	280 KW	320 KW

Applicable Voltages: 220/127 V at 60 Hz only (Consult your dealer for more details).  
\* Ratings at 0.8 Power Factor

### ENGINE / TECHNICAL DATA

Engine Make	Perkins			
Engine Model	2206A-E13TAG2			
Governing Type	Electronic			
Number of Cylinders	6			
Cylinder Arrangement	Vertical in line			
Bore and Stroke mm	130 x 157			
Displacement / Cubic Capacity litres	12.5			
Induction System	Turbocharged and air to air charge cooled			
Cycle	4 stroke			
Combustion System	Direct Injection			
Compression Ratio	16.3:1			
Rotation	Anti-clockwise, viewed on flywheel			
Cooling System	Water - cooled			
Frequency and Engine Speed	50Hz & 1500rpm		60Hz & 1800rpm	
	Prime	Standby	Prime	Standby
Gross Engine Power kW (hp)	324 (434)	368 (493)	373 (500)	407 (546)
Fuel Consumption @ 50% load L/hr	37	-	43	-
@ 75% load L/hr	54	- 80	62	- 87
@ 100% load L/hr	71		81	
Total Lubrication System Capacity litres	40	40	40	40
Total Coolant Capacity litres	51.4	51.4	51.4	51.4
Boost Pressure Ratio	2.8	3.2	3.1	3.4
Exhaust Temperature: °C	630	630	630	660
Radiator Cooling Air Flow (Min): m3/sec	9.4	9.4	12.0	12.0
Combustion Air Flow: m3/min	21.3	23.6	27.4	29
Exhaust Gas Flow: m3/min	56.6	64.8	67.5	73.5

### STANDARD SPECIFICATIONS

#### 1. ENGINE

Perkins four stroke heavy duty high performance industrial type diesel engine.

#### 2. ENGINE FILTRATION SYSTEM

- Cartridge type dry air filter.
- Cartridge type fuel filter.
- Full flow lube oil filter.
- Water filter.

All filters have replaceable elements.

#### 3. COOLING RADIATOR

Radiator and cooling fan, complete it safety guards, designed to cool the engine at high ambient temperatures (consult your dealer for de-rating factors).

#### 4. EXHAUST SYSTEM

Heavy duty Industrial Exhaust Silencer.

#### 5. CIRCUIT BREAKER TYPE

ABB 3 pole MCCB. (4 pole is optional).

### ALTERNATOR DATA

Make	Model
Leroy Somer	LSA47.2VS2
Stamford	HC444E
No. of bearings	1
Insulation class	H
Total Harmonic Content	<2.5%
Wires	12
Ingress Protection	IP23
Over speed	2250 mn-1
Voltage Regulation	3 0.5%

# Features

Size	LXWXH (CM)	Weight (kg)
Open Type	335*113*207	3366

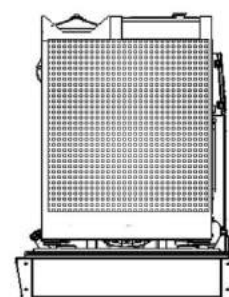
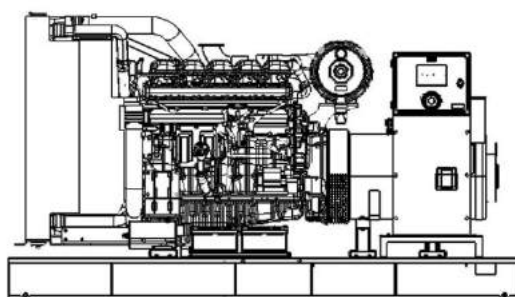
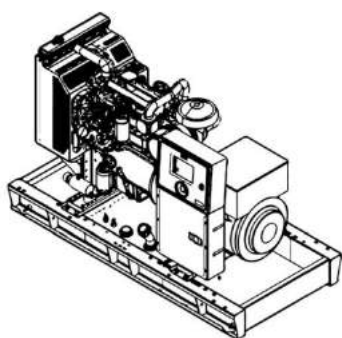

# Control Panel

The DSE6110 is an Auto Start Control Module for single genset applications. It includes a backlit LCD display which clearly shows the status of the engine all the times. This module can either be programmed using the front panel or by using the DSE configuration suite PC software.

**Metering and Alarm indications:**

- Generator frequency
- Under speed, Over speed
- Generator volts (L-L, L-N)
- Generator current
- Engine oil pressure
- Engine coolant temperature

- Hours run counter
- Battery volts
- Fail to start/stop
- Emergency stop
- Charge fail
- CAN diagnostics and CAN fail/error



## RATINGS DEFINITION

### Prime Power

These ratings are applicable for supplying continuous electrical power (at variable load) in lieu of commercially purchased power. 10% overload power is available for 1 hour in 12 hours continuous operation.

### Standby Power

These ratings are applicable for supplying continuous electrical power (at variable load) in the event of a utility power failure. No overload is permitted on these ratings

## STANDARD REFERENCE CONDITIONS

Output ratings are presented at 25°C air inlet temperature, barometric pressure 100 kPa, relative humidity 30%. This generating set is designed to operate at high ambient temperatures (up to 55°C), humidity (up to 99%) and higher altitudes. De-ration may apply, please consult your dealer for specific site ratings.

## AVAILABLE OPTIONS & ACCESSORIES

We offer a range of optional features and accessories to tailor our generating sets to meet your power needs.

### ACCESSORIES

- Genuine spare parts
- Auxiliary fuel tanks
- Manual & automatic transfer switches

### OPTIONS

- A variety of generating set control and synchronizing panels
- Water fuel separator
- Water jacket heater
- Battery charger

- Due to continuous product development we reserve the right to change specifications at any time without prior notice

## STANDARD SPECIFICATIONS

### 6. ALTERNATOR

#### 6.1 INSULATION SYSTEM

The insulation system is Class H. All windings are impregnated in either a triple dip thermosetting liquid, oil and acid resisting polyester varnish or vacuum pressure impregnated with a special polyester resin.

- Heavy coat of antitracking varnish additional protection against moisture or condensation.

#### 6.2 AUTOMATIC VOLTAGE REGULATOR (AVR)

The fully sealed Automatic Voltage Regulator maintains the Voltage Regulation at 30.5%. Nominal adjustment by means of a trim pot incorporated on the AVR.

#### 6.3 MOTOR STARTING

An overload capacity equivalent to 300% of the Full Load impedance at zero Power Factor can be sustained for 10 seconds, when AREP or PMG option is fitted.

### 7. MOUNTING ARRANGEMENT

#### 7.1 BASE FRAME

The complete Generating Set is mounted as a whole on a heavy duty fabricated steel Baseframe.

#### 7.2 COUPLING

The Engine and Alternator are directly coupled by means of an SAE flange. The Engine flywheel is flexibly coupled to the Alternator rotor.

**7.3 ANTI-VIBRATION MOUNTING PADS** Anti-Vibration pads are affixed between the Engine / Alternator feet and the Base frame thus ensuring complete vibration isolation of the rotating assembly.

#### 7.4 SAFETY GUARDS

The Fan & Fan Drive along with the Battery Charging Alternator are Safety Guard protected for personnel protection.

### 8. FACTORY TESTS

The Generating set is load tested before dispatch. All protective devices control functions and site load conditions are simulated. The generator and it's systems are checked before dispatch.

### 9. EQUIPMENT FINISHING

All mild steel components are fully degreased and painted with powder coated paint to ensure maximum scuff resistance and durability.



## **SULAYMANIYAH OFFICE**

MAILK MAHMUD RING ROAD | NEAR BINAHEY OIL STATION |  
SULAIMANYA | KRG-IRAQ TEL: 0964 750 155 3355



## **ERBIL OFFICE**

MAKHMOR ROAD | KURRAN | OPPOSITE KHDR SWARA  
MOSQUE | ERBILKRG-IRAQ | TEL : 0964 750 150 0527

## **FACTORY**

SOUTH INDUSTRIAL AREA | TRACTOR INDUSTRIAL| ERBIL | KRG-IRAQ  
TEL: 0964 750 050 0490

## **MUSL OFFICE**

POTATO'S STORE POINT | BEHAND INDUSTRIAL HIGH  
SCHOOL |3RD STREET | MUSL | IRAQ  
TEL: 0964 770 201 2305

## **SPARE PART SULI**

SARKAREZ | NEAR ASOI DALAK INTERSECTION | SULAIMANYA | KRG-IRAQ  
TEL: 0964 773 150 3655

## **SPARE PART ERBIL**

SOUTH INDUSTRIAL AREA| MID OF 3RD STREET | ERBIL | KRG-IRAQ  
TEL: 0964 750 300 3355

## **SERVICE WORKSHOP**

OLD INDUSTRIAL AREA | OPPOSITE AUBARA QRT. | SULAIMANYA | KRG-IRAQ  
TEL: 0964 750 050 0285

[WWW.DIARY-SUPPLIES.COM](http://WWW.DIARY-SUPPLIES.COM)  
[INFO@DIARY-SUPPLIES.COM](mailto:INFO@DIARY-SUPPLIES.COM)

